

FRESH-AIRE UV[®]

COMMERCIAL SERIES

PANEL MOUNT SYSTEM

Panel Mount System

Panel Mount System: easy, flexible installation with advanced multi-voltage water-resistant power supply featuring the Triatomic lifetime power supply warranty. The panel mount allows installations in the most difficult, hard to reach areas by allowing access to the coil from the outside of the system. This system effectively kills mold, bacteria, and viruses in hvac equipment. You will save energy by keeping the system cleaner, lowering maintenance costs and reducing chemical exposure to maintenance workers.

FEATURES

- High quality water-resistant shielded lamps
- Multi-voltage water-resistant power supply
- Easy, flexible installation – allows installation in the tightest of locations.
- Triatomic lifetime power supply warranty
- Easy, flexible installation

BENEFITS

- Kills mold, bacteria, and viruses in the HVAC system
- Saves energy by keeping components cleaner
- Lowers maintenance costs – reduced cleanings
- Reduces worker exposure to chemicals
- Cost effective

Shielded 2 year water-resistant UV lamp



External installation up to 4' x 4' coils.



Lifetime multi-voltage water-resistant power supply

Lamp Options



Standard Output
1 Year Lamp



Standard Output
2 Year Lamp



High Output
1 Year Lamp



FRESH-AIRE UV[®] products are manufactured by:
TRIATOMIC ENVIRONMENTAL, INC.
sales@freshaireuv.com



WWW.FRESHAIREUV.COM

FRESH-AIRE UV[®]

COMMERCIAL SERIES

PANEL MOUNT SYSTEM

Panel Mount Technical Drawings

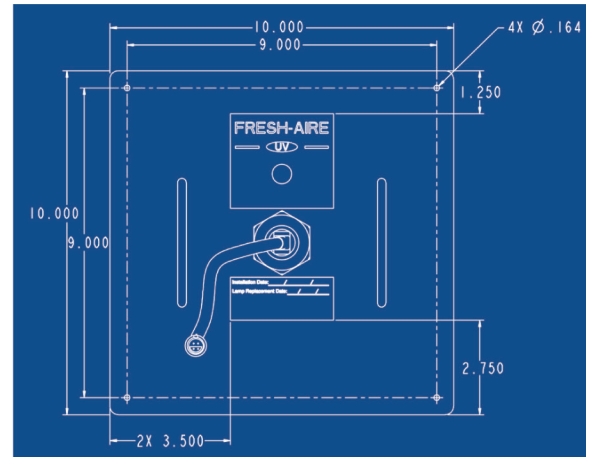
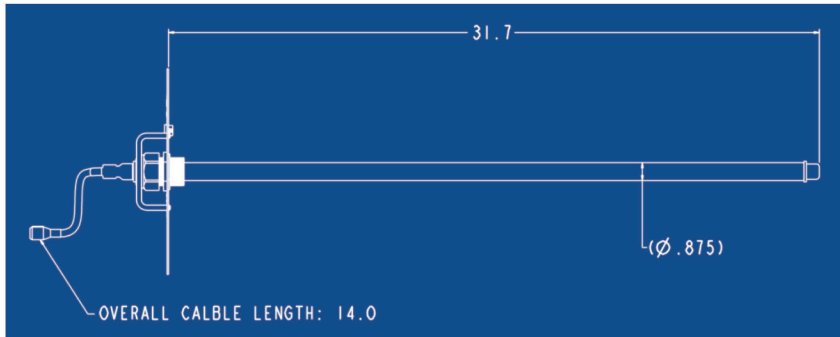

Panel Mount Specifications

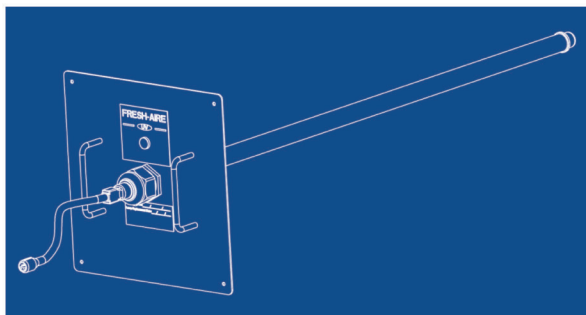

Lamp configuration	Standard 1 (S), 2 (D), 3 (T), 4(Q) High Output 1 (S), 2 (D)
Dimensions	S-D Power supply: 8.75"L x 3.75"W x 2.5"H T-Q Power supply: 13"L x 3.75"W x 2.5"H Panel -10"L x 10"W x 2.5"D Lamp: 32"L x 0.875 Dia.
Weight	6 Lbs.
Electrical standard output	Normal output auto switching multi-voltage 120 - 277 VAC, 1.2-0.60 Amps
Electrical high output	High output auto switching multi-voltage 120 - 277 VAC, 1.88-0.8 Amps
Kit includes	Remote power supply, 6' lamp cable, 6' power cord, UV lamp, panel mounting brackets, mounting hardware and panel indicator
1 Year UV Lamp standard output	Quartz hot filament (Teflon [®] coating available) 150 mw/cm ² @ 1 meter
2 Year UV Lamp standard output	Shielded quartz hot filament with filament guard 140 mw/cm ² @ 1 meter
1 Year UV Lamp high output	Quartz hot filament 300 mw/cm ² @ 1 meter Output per 1" arc length of not less than 10 µW/cm ² at 1 meter in a 400 fpm airstream of 45° F
Warranty	1 year & high output lamps - 1 Year 2 year standard lamp - 2 Years Power supply - Lifetime

Part Numbers
1 Year Lamp
TUVC-100S-P (single)
TUVC-100D-P (dual)
TUVC-100T-P (triple)
TUVC-100Q-P (quad)
2 Year Lamp
TUVC-200S-P (single)
TUVC-200D-P (dual)
TUVC-200T-P (triple)
TUVC-200Q-P (quad)
1 Year Lamp High Output
TUVC-100S-HO-P (single)
TUVC-100D-HO-P (dual)