

US patent #7,704,463

Installation Guide

APCO® RT reduces odors (volatile organic compounds) and biological contaminants such as mold, bacteria, viruses, and allergens in indoor air. The system is installed in the duct work of the central air system. The award-winning design of APCO® RT uses a unique combination UVC light and activated carbon cells to clean the air.

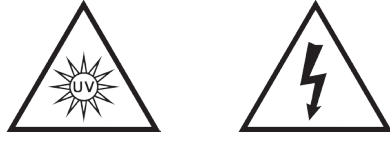

IMPORTANT!

- Only qualified technicians should install this product*
- Install in accordance with relevant building codes
- Read instructions carefully including safety warnings

WARNING!

PROTECT EYES FROM UV LIGHT
TURN OFF UNIT OR DISCONNECT
BEFORE SERVICING

*Installation of this product by anyone other than licensed HVAC or electrical contractors voids warranty.
© 2016 Fresh-Aire UV TUV-APCORT-MAN 4.27.16

1 Installation Notes

APCO® RT is usually installed on the supply side duct just above the air system but can also be installed on the return side if necessary.

The APCO® RT unit should be oriented so that the air flows past the UV Light first then into the Matrix Element.

If a second optional UV lamp is used (APCO® RT Dual) select a location inside the air system that will allow it to shine on the greatest surface area or the area with the most evident microbial growth. To install the secondary UV light use the Optional 2nd Remote UV Light Installation Instructions provided with APCO® RT Dual.

Typical installations include:

- A** APCO RT single in air handler
- B** APCO RT dual in air handler
- C** APCO RT single in Furnace
- D** APCO RT dual in Furnace

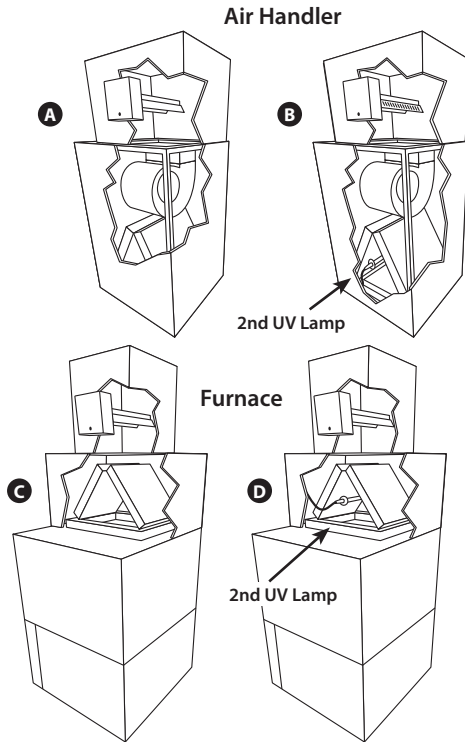

1 Parts List

- A** APCO RT Main Unit
- B** RT UV Lamp 1 Year*
- C** RT UV Lamp 2 Year*
- D** Backing Plate
- E** Gasket
- F** ER Power Supply*
- G** ST/DT Power Supply*
- H** SI/DI Power Supply*
- I** Self-tapping Screws
- J** Machine Screw
- K** Quick Nut (plastic)
- L** Tap-in Connector
- M** Spade Connector
- N** Optional Remote UV Lamp 1 Year
- O** Optional Remote UV Lamp 2 Year
- P** Sight Glass
- Q** "Z" Mounting Bracket
- R** Warning Sticker

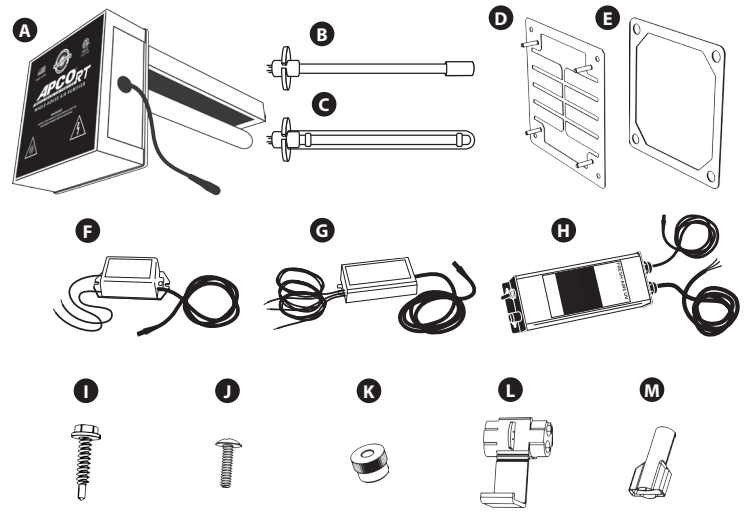

*Note: only one lamp and one power supply are included with APCO RT.

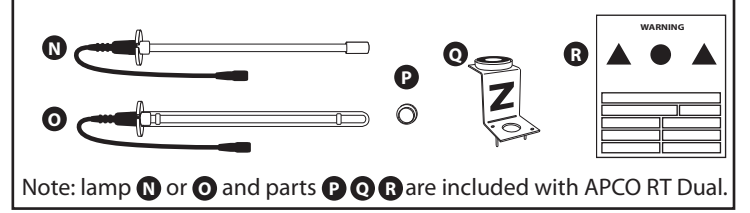

Note: lamp **N** or **O** and parts **P** **Q** **R** are included with APCO RT Dual.

2 Duct Mounting

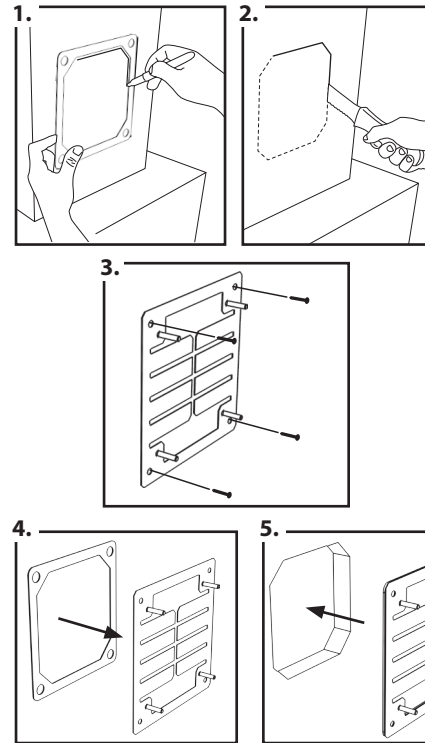

1. Use gasket to trace cut-line onto duct.
 2. Cut hole in sheet metal or duct board.
IMPORTANT! Remove and dispose of cut-out piece of material.
 3. For sheet metal duct secure mounting plate to sheet metal ducts using self-tapping screws.*
 4. Remove paper backing from one side of gasket and fix gasket to the back of the mounting plate.
 5. Remove paper backing from back of gasket then fix mounting plate and gasket to the duct.
 6. Bend mounting plate flanges around the edges of the hole to secure mounting plate. For duct board use tape on edges of mounting plate for air leaks and additional hold.
- * To install APCO RT without backing plate mount with (4) self-tapping screws.

3 Attach Lamp Housing to Duct & Connect UV Lamp

1. Fit the APCO® RT Main Unit through hole in duct. Attach directly to metal duct using (4) Self-tapping Screws. If the Backing Plate is used fit the unit over the threaded posts and use (4) Quick Nuts to secure it.
2. Connect UV Lamp (be sure to align the four connector pins).
3. Attach the cover with machine screws.

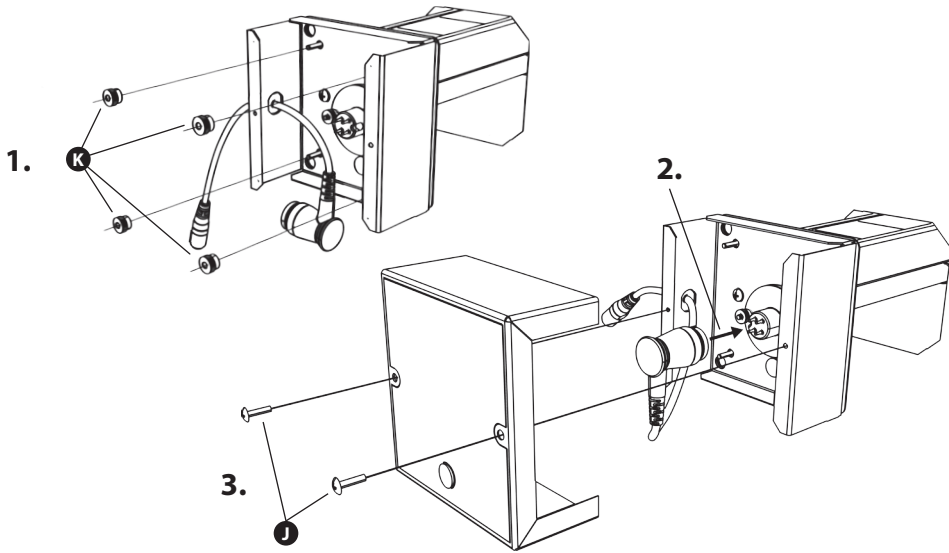

4 Connecting to Power

IMPORTANT

Before connecting to power confirm which APCO® RT model is being installed. Turn off main power source before installation. Model information is printed on the Power Unit cover.

IMPORTANT! Must be wired to constant power - do not connect to blower relay.

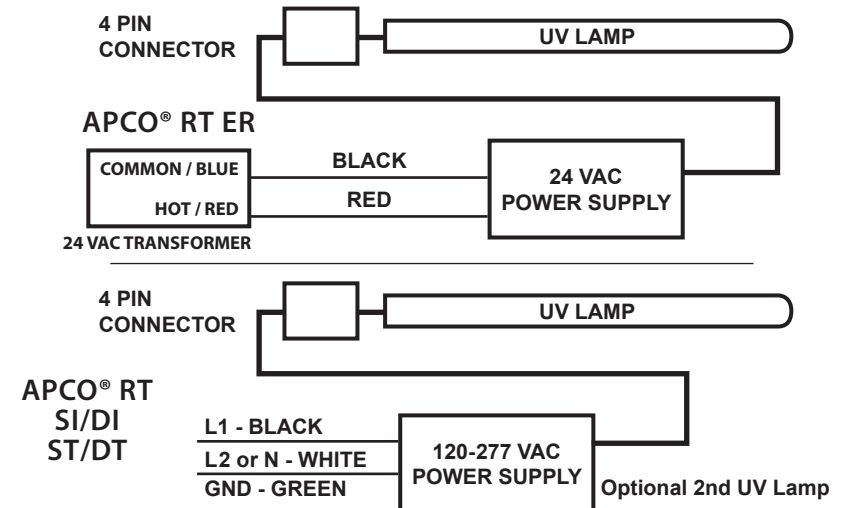

IMPORTANT!

Systems with high 24 VAC loads may require the installation of a separate 24 VAC transformer to power the UV light.

Always use a separate 24 VAC transformer with "communicating" air systems and all APCO® Dual (TUV-APCO-DER) models.

Draws 16 VA, may need to do load calculation: Volts under load X Amps under load.

5 Lamp Replacement

The germicidal UV lamp in APCO® RT needs to be replaced periodically. TUVL111 lamps should be replaced every year. TUVL211 should be replaced every 2 years. Note: UV lamps will continue to emit visible light but lose germicidal effectiveness over time. You can upgrade to a 2 year lamp with your existing APCO® RT Power Unit.

B TUVL111 (1 Year)

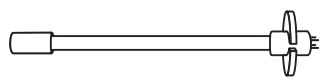

G TUVL211 (2 Year)

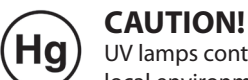

CAUTION!

UV lamps contain small amounts of mercury - dispose of lamps in accordance with local environmental regulations. For more information visit www.lamprecycle.org

Note: Use of replacement UV lamps other than Fresh-Aire UV® voids warranty.

Manufacturer's Warranty:

This warranty supersedes and replaces any warranty statements orally made by the Sales Person, Distributor or Dealer or contained in the written instructions or other Brochures or informational documents in relation to this product. This warranty gives you specific legal rights, and you may also have other rights which vary from State to State.

What Does This Warranty Cover? This lifetime limited manufacturer warranty covers any defects or malfunctions in material and workmanship under the normal use and service when operated and maintained in strict accordance with manufacturer's instructions for the Lifetime of the equipment.

How Long Does The Coverage Last? 1) Power Supply: For as long as you own the real property where the product is installed. 2) TUVL-1XX Series Ultraviolet Lamp is warranted for germicidal output for one-year from the date of installation. 3) TUVL-2XX Series Ultraviolet Lamp is warranted for germicidal output for two (2) years from the date of installation. This warranty is not transferable.

What Will Triatomic Environmental, Inc. Do? Triatomic Environmental, Inc. will replace any defective or malfunctioning part at no charge. You must pay any labor charges and shipping charges of defective product to our warranty department.

What Does This Warranty Not Cover? THIS PRODUCT IS NOT INTENDED TO BE PURCHASED AND INSTALLED BY UNLICENSED HVAC OR ELECTRICAL CONTRACTORS. This warranty does not cover products or parts purchased from any source other than licensed HVAC or electrical contractors. This warranty does not cover parts installed by unlicensed HVAC or electrical contractors. This warranty does not cover parts damaged as a result of misuse, abuse, or any use other than its intended use, accident, acts of god, neglect, or from improper operation, maintenance, installation, modification or adjustments. Triatomic Environmental, Inc. shall have no responsibility for charges incurred by the customer for installation or removal of warranted items.

This warranty does not cover parts or equipment used with the Fresh-Aire UV system that are not manufactured by Triatomic Environmental, Inc.

**This warranty shall be void if UV lamps from manufacturer's other than Triatomic Environmental, Inc. are used with this equipment. Consequential and incidental damages are not recoverable under this warranty. Manufacturer assumes no liability for any harm, which may occur as a result of the use of the equipment herein and shall not be liable for consequential or any other damages whether or not caused by manufacturer's negligence or resulting from any express or implied warranty or breach thereof. Consequential damages for the purpose of this warranty shall include, but not be limited to, loss of use, income or profit, or loss of or damages to property or injury or death to persons or animals occasioned by or arising out of operation, use, the operation, installation, repair or replacement of the equipment or otherwise. Some states do not allow the exclusion or limitation of incidental or consequential damages, so the above limitation or exclusion may not apply to you.

There are no Warranties which extend beyond the description of the face hereof.

How Do You Get Service? In order to be eligible for service under this warranty you MUST return the warranty registration card or register online at www.freshaireuv.com. If something is wrong with your product, call your installing contractor to receive a Return Merchandise Authorization (RMA) and instructions for returning the product to a licensed distributor in your area or the manufacturer.

Once the product is returned, we will inspect your product and contact you within 10 business days of our receipt of the product to give the results of our inspection. If we determine that the product is covered under this warranty, we will ship to you at no additional cost a replacement part. Replacement parts may be refurbished. If we determine that the product is not covered under this warranty, or that this warranty is void, the product will be returned to you COD. There is no charge for inspection.

How Does State Law Apply? This warranty gives you specific legal rights, and you may also have other rights which vary from state to state.

Optional 2nd Remote UV Light Installation Instructions

The optional Fresh-Aire Remote UV Light works with the APCO® RT system for enhanced disinfection, reduced system maintenance, and improved indoor air quality.

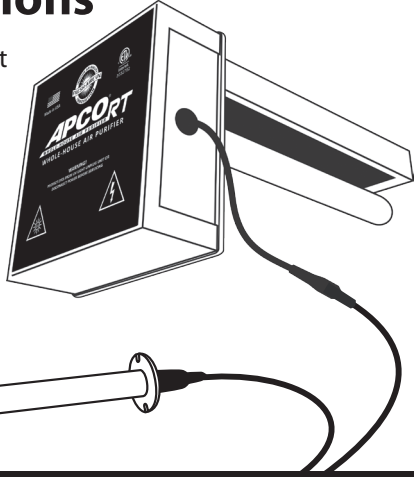

- IMPORTANT!**
- APCO Dual lamps are wired in series - both must be connected for lamps to light
 - Only qualified technicians should install this product
 - Install in accordance with relevant building codes
 - Read instructions carefully including safety warnings

Installation Notes

Before installing the Fresh-Aire Remote UV Light it is necessary to determine the optimal mounting location inside the air system. First, look for the area with the heaviest mold growth. Also consider a location that will allow the germicidal UV light to shine on the greatest surface area.

Some typical mounting locations:

- **A** Across top of coils
- **B** Coil "A" plate
- **C** Return-side duct



Important: some materials inside the air system (including filter media, flex duct, wiring etc.) may not be UV light resistant. Use the optional UV shield (part #TUV-SHIELD-LPC) or cover the materials with reflective tape.

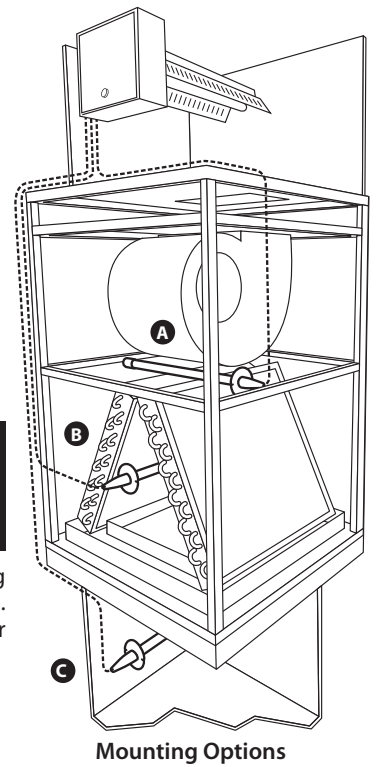

Mounting Options

1 Air Handler Interior Surface Installation

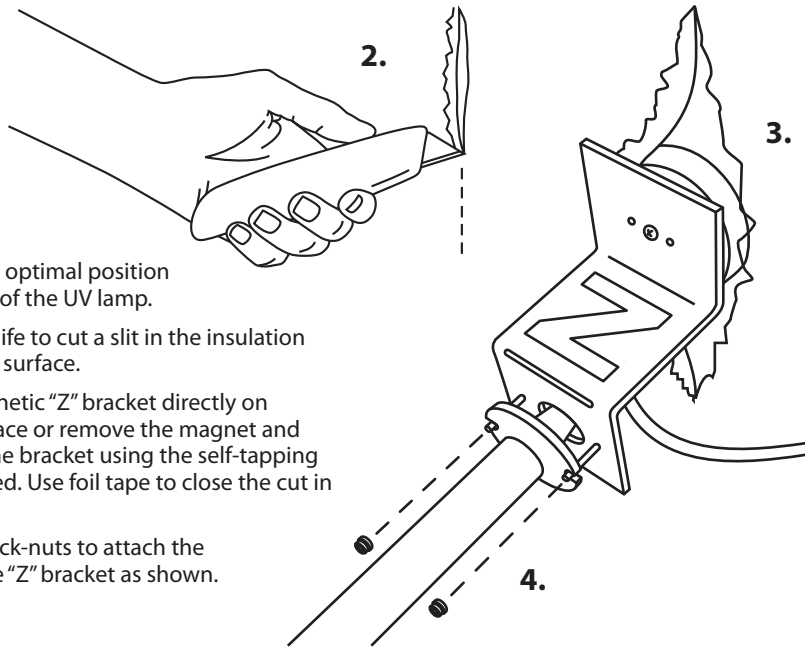

1. Determine the optimal position for placement of the UV lamp.
2. Use a utility knife to cut a slit in the insulation on the interior surface.
3. Place the magnetic "Z" bracket directly on the metal surface or remove the magnet and hard-mount the bracket using the self-tapping screws provided. Use foil tape to close the cut in the insulation.
4. Use plastic quick-nuts to attach the UV lamp to the "Z" bracket as shown.

2 Coil "A" plate or Duct Installation

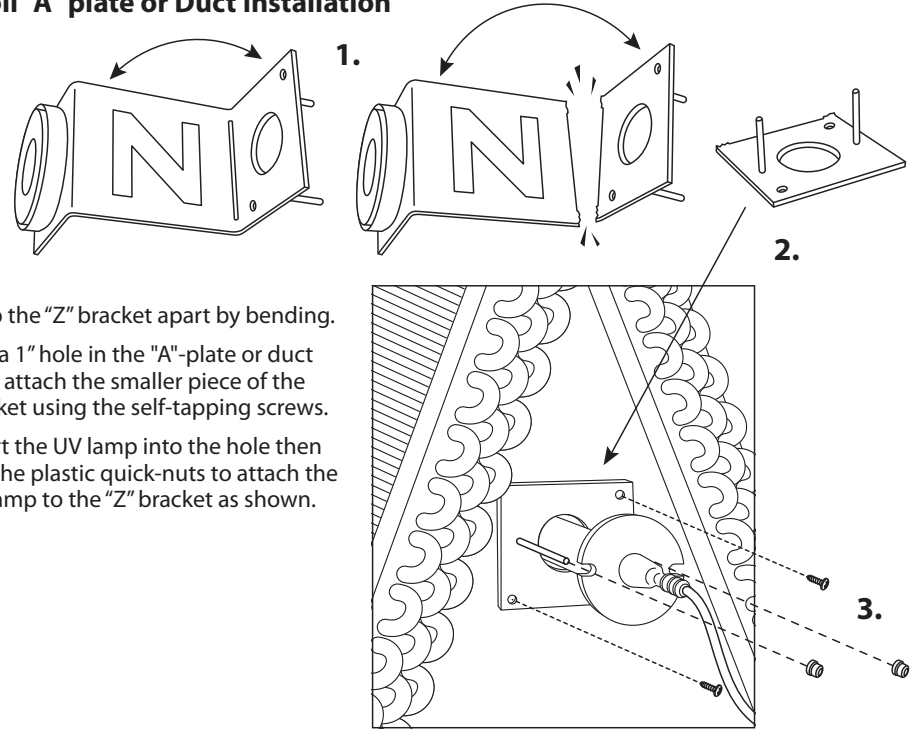

1. Snap the "Z" bracket apart by bending.
2. Drill a 1" hole in the "A"-plate or duct then attach the smaller piece of the bracket using the self-tapping screws.
3. Insert the UV lamp into the hole then use the plastic quick-nuts to attach the UV lamp to the "Z" bracket as shown.

3 Remote UV Light Configuration

IMPORTANT! Only the APCO® RT Dual model has the electrical capacity and attached cable for the optional Remote UV Light. Simply connect the lamp lead to the power cable on the left side of the APCO® Power Unit.

To add a second UV light to an existing APCO® RT system that is not a Dual model install a separate Fresh-Aire UV AHU Series 1 or Blue-Tube UV system.

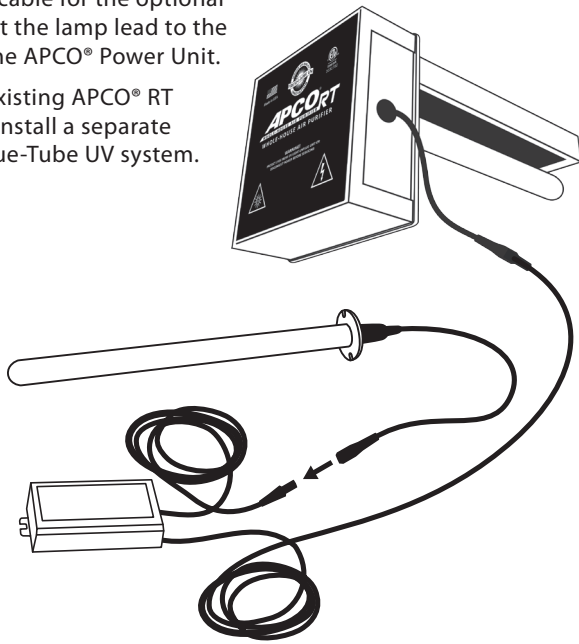

4 Sight Glass Installation

1. Find a suitable location on the outside of the duct-work near the UV Lamp installation and apply the Fresh-Aire UV® warning/lamp replacement sticker.
2. Drill a ½" hole through the orange circle on the sticker. Press the UV safety viewport into hole.
3. Turn on the power and use the sight glass to confirm that the UV Lamp is operating.

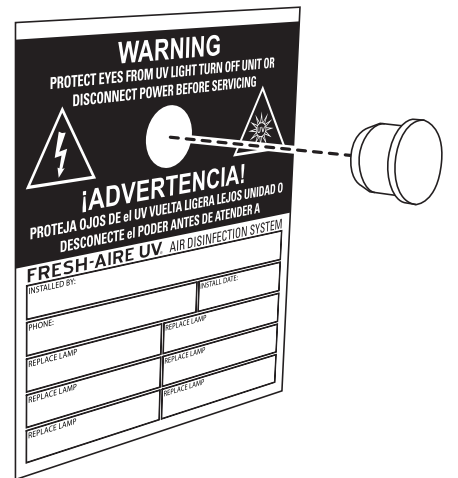

5 Remote UV Lamp Connection

1. When all the other components are properly installed connect the UV Lamp cable to the APCO® RT Power supply cable.
2. Make sure the flanges are aligned and then push the connectors firmly together. A tight connection ensures a proper water-resistant seal.

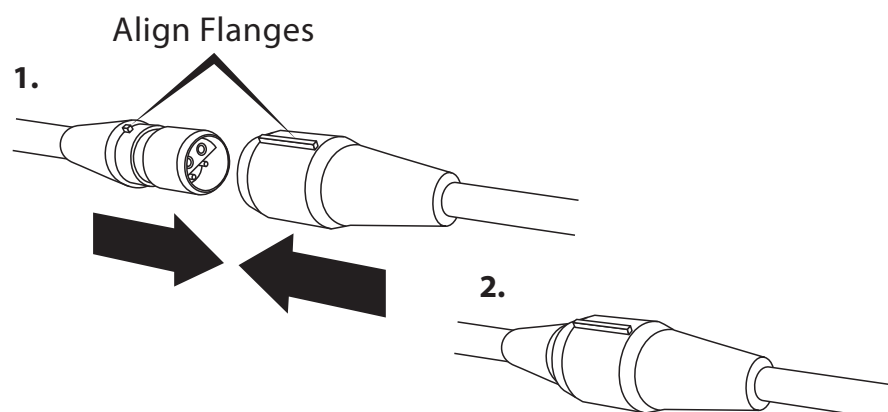

6 Lamp Replacement

The germicidal UV lamp in the Fresh-Aire Remote UV Light needs to be replaced periodically. A TUVL-115P lamp should be replaced every year. The TUVL-215P should be replaced every 2 years. Note: UV lamps will continue to emit visible light but lose germicidal effectiveness over time. You can upgrade to a 2 year with your existing power supply.

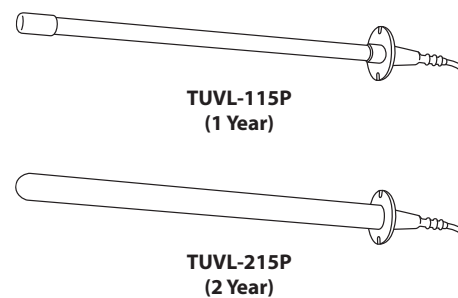

Hg CAUTION! UV lamps contain small amounts of mercury - dispose of lamps in accordance with local environmental regulations. For more information visit www.lamprecycle.org

Note: Use of replacement UV lamps other than Fresh-Aire UV® voids warranty.